



Price list

FOODSERVICE *Novelties*



2026

EN



ÍNDEX

| | |
|--------------------------------------|-----------|
| Cooking | 04 |
| — Microwave | 05 |
| — Drop-in | 06 |
| — Countertop induction cookers | 08 |
| — Heated display | 09 |
| | |
| Ovens | 10 |
| — Speed Oven..... | 11 |
| | |
| Dynamic preparation | 12 |
| — Cold meat slicers..... | 13 |
| — Vegetable cutters | 17 |
| — Meat mincers | 18 |
| — Cutters..... | 19 |
| — Arm shredders | 20 |
| — Potato peelers..... | 23 |

 Cooking

COMPLETE
your cooking space.

AVAILABLE IN **SEPTEMBER**

Complete the cooking space, providing comfort, efficiency, and seamless integration into professional kitchens.

Simple. Functional. Professional.

INDEPENDENT COOKING

Microwave



CI-MW2

General Features

- Manufactured in satin-finish stainless steel.
- Intuitive and easy-to-use control panel.
- Programming of up to 100 programs, with a maximum of 60 minutes per program.
- 5 power levels and up to 3 cooking stages per program.
- Direct time input, X2 program to double quantities, and defrost option.
- Manual mode, LED display, and end-of-cycle buzzer.
- Power input: 1500 W / Output power: 1000 W via one magnetron.
- Flat ceramic base, facilitating cleaning by eliminating the glass turntable.
- Transparent door and smooth surfaces, designed for easy cleaning.
- Removable filter, allowing maintenance operations to be carried out easily.

Codes and prices

| MODEL | CODE | CAPACITY(L) | VOLTAGE | POWER (W) | DIMENSIONS (MM) | € |
|--------|----------|-------------|---------------|-----------|-----------------|---|
| CI-MW2 | 19114234 | 25 | 230 V 1N 50Hz | 1000 | 511x431x311 | - |

INDEPENDENT COOKING – DROP-IN

Induction hob



CD-CIE604 2

380-415V

General features

- Manufactured in satin-finish stainless steel.
- Energy is supplied only to the area where the cookware is placed, while the rest of the glass-ceramic surface remains cool. When the cookware is removed, heating stops.
- High-resistance glass-ceramic, 6 mm thick, resistant to thermal shock.
- 11-level power regulator, allowing low power for delicate recipes or maximum power for fast service.
- Control panel with 0,6 meters of cable, allowing installation in the furniture where the drop-in element is built in.
- Structure with a 15 mm thick supporting surface for flush mounting on the countertop, improving cleaning and aesthetics.

Codes and prices

| MODEL | CODE | COOKING ZONE | | | BUILT-IN DIMENSIONS (MM) | POWER (W) | DIMENSIONS (MM) | € |
|-------------|----------|--------------|--------|----------------|--------------------------|-----------|-----------------|---|
| | | QUANTITY | Ø (MM) | ZONE POWER (W) | | | | |
| CD-CIE604 2 | 19115446 | 2 | 280 | 5000 | 350x577 | 10000 | 400x625x316 | - |

INDEPENDENT COOKING – DROP-IN

Induction fry top



CD-FTE604 1

380-415V

General features

- Manufactured in satin-finish stainless steel.
- Smooth mild steel plate, 10 mm thick, hard chrome plated.
- Adjustable temperature range: from 80 °C to 300 °C, with multiple steps.
- Control panel with 0,6 meters of cable, allowing installation in the furniture where the drop-in element is built in.
- Structure with a 15 mm thick supporting surface for flush mounting on the countertop, improving cleaning and aesthetics.
- Grease collection channel along the entire front perimeter for hygienic and safe maintenance.
- Easily removable lateral and rear splash guard.
- Drain hole for collecting cooking grease and space designed to place a GN1/9 container (not included) for storage.

Codes and prices

| MODEL | CODE | GRIDDLE | | BUILT-IN DIMENSIONS (MM) | POWER (W) | DIMENSIONS (MM) | € |
|-------------|----------|---------------|-----------------|--------------------------|-----------|-----------------|---|
| | | COOKING ZONES | DIMENSIONS (MM) | | | | |
| CD-FTE604 1 | 19115443 | 1 | 320x460 | 360x587 | 5000 | 400x625x316 | - |
| CD-FTE608 1 | 19115444 | 1 | 720x460 | 760x587 | 5000 | 800x625x316 | - |

INDEPENDENT COOKING – DROP-IN

Induction pasta cookers



CD-CPE60 15

380-415V

General features

- Manufactured in satin-finish stainless steel.
- Tank made of AISI 304 stainless steel, 1.5 mm thick.
- Adjustable temperature range: from 60 °C to 100 °C, with multiple steps.
- Control panel with 0,6 meters of cable, allowing installation in the furniture where the drop-in element is built in.
- Structure with a 15 mm thick supporting surface for flush mounting on the countertop, improving cleaning and aesthetics.
- Tank filling via solenoid valve with two-position selector: medium filling speed and high speed.
- Integrated drain tap for safe and hygienic water draining, avoiding direct contact and facilitating maintenance. Includes safety overflow.
- Removable drainer located at the front to support baskets.
- Included accessories:
 - 1 GN1/3 basket
 - 2 GN1/6 baskets

Codes and prices

| MODEL | CODE | QUANTITY | TANK | | BUILT-IN DIMENSIONS (MM) | POWER (W) | DIMENSIONS (MM) | € |
|--------------|----------|----------|--------------|-----------------|--------------------------|-----------|-----------------|---|
| | | | CAPACITY (L) | DIMENSIONS (MM) | | | | |
| CD-CPE604 15 | 19115445 | 1 | 15 | GN2/3 | 360x587 | 5000 | 400x625x316 | - |

INDEPENDENT COOKING – DROP-IN

Induction fryer



CD-FE604 10

380-415V

General features

- Manufactured in satin-finish stainless steel.
- Adjustable temperature range: from 60 °C to 190 °C, with multiple steps.
- Control panel with 0,6 meters of cable, allowing installation in the furniture where the drop-in element is built in.
- Structure with a 15 mm thick supporting surface for flush mounting on the countertop, improving cleaning and aesthetics.
- Integrated drain tap for safe and hygienic draining of used oil, avoiding direct contact and facilitating maintenance.
- Included accessories:
 - Basket dimensions: 190 x 230 x 145mm.
 - Tank lid.

Codes and prices

| MODEL | CODE | QUANTITY | TANK | | BUILT-IN DIMENSIONS (MM) | POWER (W) | DIMENSIONS (MM) | € |
|-------------|----------|----------|--------------|---------|--------------------------|-----------|-----------------|---|
| | | | CAPACITY (L) | BASKETS | | | | |
| CD-FE604 10 | 19115442 | 1 | 10 | 1 | 360x587 | 5000 | 400x625x316 | - |

Induction countertop



CI-I140 1



CI-I145 2

General features

- Countertop induction hob. Ideal for kitchens, auxiliary areas, or cooking outside the usual space such as show cooking, outdoor catering, celebrations, or events.
- It is very convenient, with a cooking surface of up to 35 cm, ideal for professional pans, reinforced stainless steel base, support legs that provide safety and stability during cooking, and all the advantages of induction cooking such as easy cleaning and safety.
- Touch control, convenient and easy to use. Safety lock.
- The control system is fully digital. 10 temperature levels. Timer from 0 to 180 minutes.
- Includes overheating protection. Filter to prevent greasy air from entering the components. High-speed, efficient cooling fans for components.
- Temperature range 60–240°C.
- With keep-warm / heating function selector. Automatic shut-off.
- Model CI-I45 2 is a double induction hob of 3500 W, designed for small spaces. It offers maximum flexibility, allowing you to cook multiple dishes at different temperatures simultaneously. In addition, its single cooking surface makes cleaning easier and improves energy efficiency.

Codes and prices

| MODEL | CODE | TEMPERATURE (°C) | TOTAL POWER (W) | VOLTAGE | DIMENSIONS (MM) | € |
|----------|----------|------------------|-----------------|-----------------|-----------------|---|
| CI-I40 1 | 19114901 | 60-240 | 3500 | 230V 1N 50/60Hz | 383x460x90 | - |
| CI-I45 2 | 19114903 | 60-240 | 2000 + 1500 | 230V 1N 50/60Hz | 608x370x56 | - |

Heated display



CI-M60 1

General features

- Countertop tempered glass plates designed to maintain food temperature.
- Especially designed for use in all types of buffets, for holding products in fast food establishments, in pass-through areas from the kitchen, etc.
- The base and structure of the units are made of AISI-304 18/10 stainless steel.
- Temperature control by thermostat from 60 °C to 105 °C (maximum surface temperature 100 °C).
- 5 mm thick tempered glass.
- Large heating surface.
- Ideal for combination with one or more heat holding lamps.
- **IMPORTANT:** Do not place products on the glass at temperatures that may cause thermal shock (either cold or hot).

Codes and prices

| MODEL | CODE | TEMPERATURE (°C) | TOTAL POWER (W) | VOLTAGE | DIMENSIONS (MM) | € |
|----------|----------|------------------|-----------------|---------|-----------------|---|
| CI-M60 1 | 19114904 | 60-105 | 250 | 230V | 615x363x311 | - |

☰ Ovens

HEAT AT *speed.*

AVAILABLE IN **JULY**

Accelerated cooking technology to optimize time, improve performance, and meet the demands of professional kitchens.

Speed. Precision. Power.

SPEED OVEN

Accelerated Cooking Ovens

General features

- 7.8" touchscreen with independent power button.
- Customizable cooking profiles with password protection.
- Exclusive Fagor Professional recipe library with remote creation capability.
- Temperature range: 100–275°C.
- 3 preset preheating temperatures.
- Up to 6 cooking stages, with 10 minutes per stage.
- Configurable temperature band between 10 and 70°C.
- 9 fan speeds.
- 2 standard magnetrons with power regulation in 10% increments.
- Forced air system with removable air diffuser plate.
- Austenitic stainless steel cooking chamber (AISI 304) with internal halogen lighting.
- Removable and washable air filters.
- Hygienic door gasket with triple safety system and energy leakage barrier.



OS-300

| FIELD | DATA | | |
|-----------------------|---------------------|-------------------|--|
| Capacity | Cooking chamber | 314 x 343 x 175mm | |
| | Electrical power | 3 kW | |
| Power supply | Frequency | 50 Hz | |
| | Standard voltage | 230 V 1~ | |
| | Width | 400mm | |
| Dimensions and weight | Depth (with handle) | 655mm (735mm) | |
| | Height | 608mm | |
| | Net weight (gross) | 60 Kg (65 Kg) | |

Codes and prices

| MODEL | CODE | VOLTAGE | € |
|--------|----------|--------------|---|
| OS-300 | 19113867 | 230V 1N 50Hz | - |

Accessories

The equipment includes a complete set of accessories as standard.

Teflon grids



| MODEL | CODE | € |
|--------|----------|---|
| OS-A05 | 19113860 | - |

Non-stick paper



| MODEL | CODE | € |
|--------|----------|---|
| OS-A06 | 19113861 | - |

Pizza stone



| MODEL | CODE | € |
|--------|----------|---|
| OS-A08 | 19113863 | - |

Teflon tray



| MODEL | CODE | € |
|--------|----------|---|
| OS-A09 | 19113864 | - |

Rack



| MODEL | CODE | € |
|--------|----------|---|
| OS-A10 | 19113866 | - |

Stainless steel peel



| MODEL | CODE | € |
|--------|----------|---|
| OS-A07 | 19113862 | - |

Handle



| MODEL | CODE | € |
|--------|----------|---|
| OS-A12 | 19113859 | - |

Care and maintenance



| MODEL | DESCRIPTION | CODE | € |
|-------------|---|----------|---|
| CleanChef | Specialized alkaline cleaner with high degreasing capacity. | 19115224 | - |
| ProtectChef | Special protector for interior maintenance. | 19116495 | - |

 Dynamic preparation

PERFORMANCE *starts here.*

AVAILABLE IN **MAY**

Solutions designed for the real demands of professional kitchens, combining power, precision and reliability to ensure consistent results and a steady workflow, even during the busiest periods.

Robust. Versatile. Professional.

BELT

Cold meat slicers



General features

- Gravity-fed meat slicer made of anodised cast aluminium alloy, providing strength and protection against corrosion.
- Belt drive, quiet and low maintenance, ideal for regular use.
- Ventilated motor for continuous, efficient operation, helping to prevent overheating.
- Forged, hardened, thick blade.
- Fixed sharpener with double grinding wheel as standard.
- Transparent plastic hand guard.
- Blade protection ring.
- High-precision cutting thickness regulator.
- Models YSB-250 S and YSB-300 S:
 - Compact design but high cutting capacity.
 - IP 44 protection.
- Model YSB-300 P:
 - Model for more intensive use with greater power and cutting capacity.
 - Robust design with rounded shapes.
 - Blade extractor as standard.
 - Stainless steel push buttons with IP 67 protection.

Codes and prices

| MODEL | CODE | HZ | DISC DIAMETER (MM) | CUTTING CAPACITY (MM) | CUTTING THICKNESS (MM) | CARRIAGE TRAVEL (MM) | POWER (W) | VOLTAGE | € |
|-----------|----------|----|--------------------|-----------------------|------------------------|----------------------|-----------|-------------|---|
| YSB-250 S | 19114689 | 50 | 250 | 220 x 145 | 0-13 | 245 | 147 | 220-230V 1N | - |
| | 19114691 | 60 | | | | | | | |
| YSB-300 S | 19114692 | 50 | 300 | 250 x 185 | 0-13 | 285 | 210 | 220-230V 1N | - |
| | 19114693 | 60 | | | | | | | |
| YSB-300 P | 19114694 | 50 | 300 | 270 x 190 | 0-23 | 310 | 275 | 220-230V 1N | - |
| | 19114695 | 60 | | | | | | | |

Dimensions

| MODEL | A (MM) | B (MM) | C (MM) | D (MM) | E (MM) | F (MM) | G (MM) | L (MM) |
|-----------|--------|--------|--------|--------|--------|--------|--------|--------|
| YSB-250 S | 395 | 245 | 500 | 560 | 370 | 570 | 475 | 490 |
| YSB-300 S | 435 | 295 | 600 | 610 | 420 | 640 | 510 | 535 |
| YSB-300 P | 465 | 340 | 615 | 547 | 465 | 710 | 545 | 600 |

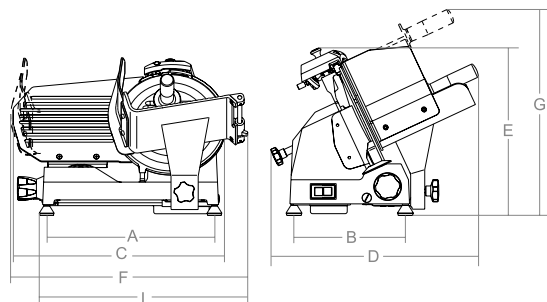

Cold meat slicers



YSG-350

General features

- Gravity-fed meat slicer made of anodised cast aluminium alloy, providing strength and protection against corrosion.
- Gear transmission, robust and durable, suitable for intensive and continuous work.
- Ventilated motor for continuous and efficient operation, helping to prevent overheating.
- Forged, hardened, thick blade.
- Fixed sharpener with double grinding wheel as standard.
- Transparent plastic hand guard.
- Blade protection ring.
- High-precision cutting thickness regulator.
- Robust design with rounded shapes.
- Blade extractor as standard.
- Stainless steel push buttons with IP 67 protection.

Codes and prices

| MODEL | CODE | HZ | DISC DIAMETER (MM) | CUTTING CAPACITY (MM) | CUTTING THICKNESS (MM) | CARRIAGE TRAVEL (MM) | POWER (W) | VOLTAGE | € |
|---------|----------|----|--------------------|-----------------------|------------------------|----------------------|-----------|-------------|---|
| YSG-350 | 19114696 | 50 | 350 | 270 x 225 | 0-23 | 310 | 400 | 220-230V 1N | - |
| | 19114697 | 60 | | | | | | | - |

Dimensions

| MODEL | A (MM) | B (MM) | C (MM) | D (MM) | E (MM) | F (MM) | G (MM) | L (MM) |
|---------|--------|--------|--------|--------|--------|--------|--------|--------|
| YSG-350 | 465 | 340 | 660 | 575 | 455 | 710 | 530 | 580 |

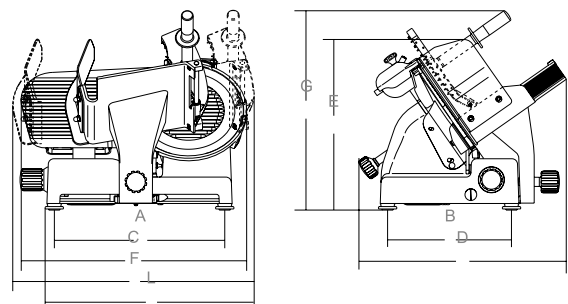

AUTOMATIC

Cold meat slicers



YSA-350

General features

- Gravity-fed meat slicer made of anodised cast aluminium alloy, providing strength and protection against corrosion.
- Belt drive, quiet and low maintenance, ideal for regular use.
- Automatic system structure made of stainless steel, with welded joints and rounded finishes.
- Ventilated motor for continuous and efficient operation, helping to prevent overheating.
- Forged, hardened, thick blade.
- Fixed sharpener with double grinding wheel as standard.
- Anodised aluminium hand guard.
- Blade protection ring.
- High-precision cutting thickness regulator.
- Robust design with rounded shapes.
- Blade extractor as standard.
- Independent controls for carriage and blade movement.
- Stainless steel push buttons with IP 67 protection.
- Automatic carriage movement with variable speed control.
- Switch for quick change between automatic and manual mode.
- Slices/minute: 4-50

Codes and prices

| MODEL | CODE | HZ | DISC DIAMETER (MM) | CUTTING CAPACITY (MM) | CUTTING THICKNESS (MM) | CARRIAGE TRAVEL (MM) | POWER (W) | VOLTAGE | € |
|---------|----------|----|--------------------|-----------------------|------------------------|----------------------|-----------|-------------|---|
| YSA-350 | 19114698 | 50 | 350 | 270 x 225 | 0-23 | 310 | 610 | 220-230V 1N | - |
| | 19114699 | 60 | | | | | | | - |

Dimensions

| MODEL | A (MM) | B (MM) | C (MM) | D (MM) | E (MM) | F (MM) | G (MM) | L (MM) |
|---------|--------|--------|--------|--------|--------|--------|--------|--------|
| YSA-350 | 465 | 340 | 690 | 575 | 575 | 756 | 630 | 615 |

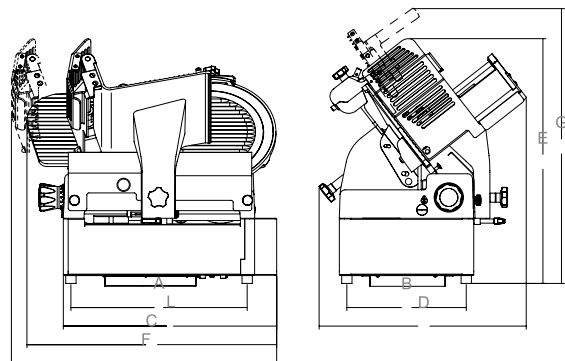

Cold meat slicers



YSR-300



YSP-300

General features

- Vertical meat slicer made of cast aluminium alloy and finished with oven-cured food-grade powder paint for greater strength and durability. With stainless steel parts and silver anodised aluminium details.
- "Retro" design ideal for hotels, gourmet restaurants, premium markets or events because it evokes quality, tradition and style. It can even increase the perceived value of the product.
- Blade traction with manual handwheel (no power supply) that allows for extremely fine and uniform cuts, without heating the product, preserving flavour, texture and aroma.
- Patented movement system with no visible mechanical parts. It incorporates a transmission mechanism that combines gears and chain, allowing the blade to rotate in a synchronised manner when the wheel is turned, while the carriage advances and exerts pressure in synchronisation with the carriage as it advances and exerts pressure

- towards the blade.
- Forged, hardened, thick blade.
- Fixed sharpener with double grinding wheel as standard.
- Blade protection ring.
- Specially articulated arm to adapt to all types of products and different sizes, with position fixing.
- Glass surface for collecting the cut product.
- High-precision cutting thickness regulator.
- Model YSP-300: Optional pedestal for YSR-300 flywheel cutter (manual), with the same red finish, supplied separately.

Codes and prices

| MODEL | CODE | DISC DIAMETER (MM) | CUTTING CAPACITY (MM) | CUTTING THICKNESS (MM) | CARRIAGE TRAVEL (MM) | € |
|---------|----------|--------------------|---|------------------------|----------------------|---|
| YSR-300 | 19114700 | 300 | 270 x 200 | 0-3 | 285 | - |
| YSP-300 | 19114701 | | Optional pedestal for retro cutter (manual) | | | - |

Dimensions

| MODEL | A (MM) | B (MM) | C (MM) | D (MM) | E (MM) | F (MM) | G (MM) | L (MM) |
|---------|--------|--------|--------|--------|--------|--------|--------|--------|
| YSR-300 | 520 | 180 | 770 | 625 | 510 | 855 | 590 | 90 |

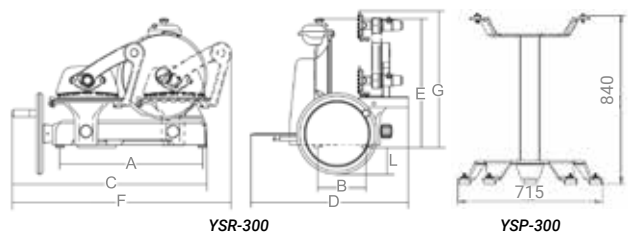

YSR-300

YSP-300

Vegetable cutters



YVC-50

General features

- Vegetable slicer made of aluminium alloy and stainless steel for strength and corrosion protection.
- Stainless steel lid suitable for dishwashers.
- Ventilated motor for continuous and efficient operation.
- Single-speed motor block.
- Optimal product evacuation thanks to its inclined design.
- Suitable for processing vegetables, but also soft products such as mozzarella, cheese, etc
- Large number of discs available for every purpose. Discs not included.
- Included as standard equipment: a GN1/3- 200mm plastic collection tray.

Codes and prices

| MODEL | CODE | HZ | CUTTING SPEED (R.P.M.) | POWER (W) | VOLTAGE | € |
|--------|----------|----|------------------------|-----------|-------------|---|
| YVC-50 | 19114702 | 50 | 300 | 515 | 220-230V 1N | - |
| | 19114703 | 60 | | | | - |

Dimensions

| MODEL | A (MM) | B (MM) | C (MM) | D (MM) | E (MM) | F (MM) | G (MM) | H (MM) |
|--------|--------|--------|--------|--------|--------|--------|--------|--------|
| YVC-50 | 225 | 195 | 225 | 280 | 510 | 400 | 510 | 770 |

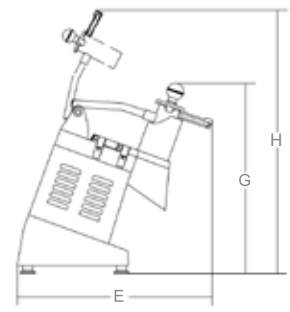
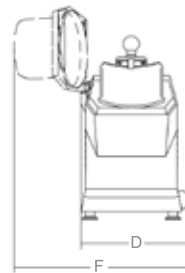
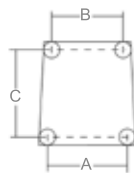
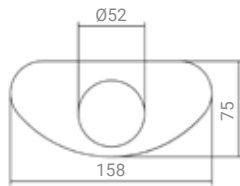

Discs

| MODEL | CODE | DESCRIPTION | CUTTING THICKNESS (MM) | € | IMAGE | | | |
|-----------|----------|-----------------------|------------------------|---|-------|--|--|--|
| YVCDF-2 | 19114704 | Disc for slices | 2 | - | | | | |
| YVCDF-5 | 19114705 | Disc for slices | 5 | - | | | | |
| YVCDF-1/7 | 19114706 | Disc for slices | 1-7 (Adjustable) | - | | | | |
| YVCDQ-4 | 19114707 | Julienne cutting disc | 4 | - | | | | |
| YVCDQ-6 | 19114708 | Julienne cutting disc | 6 | - | | | | |
| YVCDT-3 | 19114709 | Grating disc | 3 | - | | | | |
| YVCDT-7 | 19114710 | Grating disc | 7 | - | | | | |

Meat mincers



General features

- Meat mincer with motor unit casing made of:
 - YMSA and YMAA models: cast aluminium alloy that helps dissipate heat from the motor and makes it lightweight.
 - YMSS model: stainless steel, which provides strength, corrosion protection and greater hygiene.
- Ventilated asynchronous motor with thermal protection included.
- Easy-to-remove chopper unit:
 - YMSA and YMSS models in stainless steel for greater hygiene, durability and reliability. Dishwasher safe and suitable for storage in refrigerators.
- YMAA models in aluminium to reduce weight.
- With self-sharpening stainless steel blade and plate, completely removable for easy cleaning and hygiene.
- Cutting system: Entrepise.
- Included as standard:
 - One hopper.
 - A stainless steel collection tray.
 - A food-grade product pusher.
 - Outlet diameter plate: 4.5 and 6 mm.

Codes and prices

| MODEL | CODE | HZ | CHOPPER GROUP SPEED (R.P.M.) | PRODUCTION (KG/H) | POWER (W) | VOLTAGE | € |
|---------|----------|----|------------------------------|-------------------|-----------|-------------|---|
| YMAA-12 | 19114738 | 50 | 200 | 150 | 750 | 220-240V 1N | - |
| | 19114739 | 60 | | | | | - |
| YMSA-12 | 19114732 | 50 | 140 | 300 | 1100 | 220-240V 1N | - |
| | 19114733 | 60 | | | | | - |
| YMAA-22 | 19114740 | 50 | 140 | 300 | 1100 | 380-415V 3N | - |
| | 19114741 | 60 | | | | | - |
| YMSA-22 | 19114734 | 50 | 140 | 500 | 1600 | 380-415V 3N | - |
| | 19114735 | 60 | | | | | - |
| YMSS-32 | 19114736 | 50 | 140 | 500 | 1600 | 380-415V 3N | - |
| | 19114737 | 60 | | | | | - |

Dimensions

| MODEL | TOTAL DIMENSIONS (BxAxC) (MM) | INTERIOR OUTLET DIAMETER (MM) | INLET HOPPER (Y'xX'Z) (MM) | COLLECTION TRAY (MM) |
|---------|-------------------------------|-------------------------------|----------------------------|----------------------|
| YMAA-12 | 220x370x440 | 72 | 205x275x65 | 265x200x50 |
| YMSA-12 | | | | |
| YMAA-22 | 240x440x510 | 80 | 250x370x65 | 310x230x60 |
| YMSA-22 | | | | |
| YMSS-32 | 260x510x625 | 98 | 280x400x60 ⁽¹⁾ | 300x230x60 |

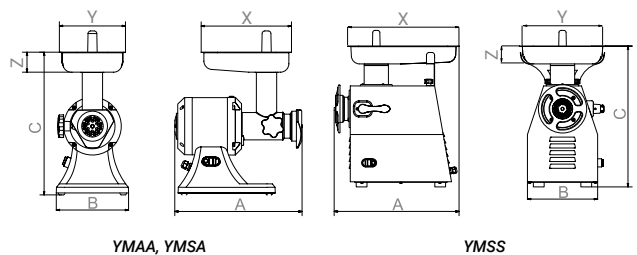

(1) Minimum width. 300 mm on the widest side

Cutters



YCV-4



YCV-6

General features

- Cutter made of aluminium for stability and quiet operation even at high speeds.
- The motor and container are located next to each other, which allows the product to be isolated from heat.
- Stainless steel container with handles, easy to empty and wash.
- Ventilated motor for continuous and efficient operation.
- Sturdy steel blades with curved edges.
- Transparent, highly resistant Tritan lid, which allows excellent visibility during processing and is dishwasher safe.
- Top hole in lid for adding ingredients during operation.
- Motor block with stabilised variable speed, allowing the speed to be maintained constant regardless of the load (quantity or type of food).
- Stainless steel push buttons with IP 67 protection.
- Includes an internal scraper with spatula for a more homogeneous mixture and to scrape the product from the walls into the container.

Codes and prices

| MODEL | CODE | HZ | USABLE CONTAINER CAPACITY (L) | CUTTING SPEED (R.P.M.) | POWER (W) | VOLTAGE | € |
|-------|----------|----|-------------------------------|------------------------|-----------|-------------|---|
| YCV-4 | 19114711 | 50 | 1,5 | 600 - 2300 | 600 | 220-230V 1N | - |
| | 19114712 | 60 | | | | | |
| YCV-6 | 19114713 | 50 | 3,1 | 600 - 2300 | 600 | 220-230V 1N | - |
| | 19114714 | 60 | | | | | |

Dimensions

| MODEL | A (MM) | B (MM) | C (MM) | D (MM) | E (MM) | F (MM) |
|-------|--------|--------|--------|--------|--------|--------|
| YCV-4 | 185 | 369 | 251 | 457 | 296 | 300 |
| YCV-6 | 185 | 369 | 251 | 457 | 304 | 362 |

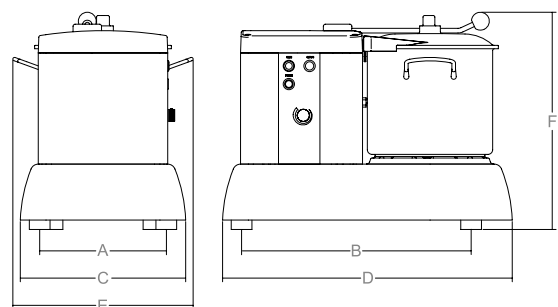

FIXED SPEED

Arm shredders



YBFAM-250

General features

- Motor block housing made of highly resistant food-grade plastic for reduced weight and fatigue relief.
- The YBFAM-250 model comes complete with a removable 250 mm shredding arm.
- Ergonomic handles for a good grip and improved user ergonomics.
- Ventilation grilles on the top for better motor ventilation and to prevent overheating.
- Thermal overload protection included.
- Fixed speed.
- High-strength polymer threaded arm connection for easy and secure assembly.
- Fully removable stainless steel shafts for easy cleaning and maintenance.

Codes and prices

| MODEL | CODE | HZ | SPEED (R.P.M.) | POWER (W) | CAPACITY (L MIN-MAX) | VOLTAGE | WEIGHT (KG) | € |
|-----------|----------|-------|----------------|-----------|----------------------|-------------|-------------|---|
| YBFAM-250 | 19114717 | 50/60 | 15.000 | 250 | 1 - 20 | 220-240V 1N | 1,45 | - |

Dimensions

| MODEL | Ø A (MM) | B (MM) | C (MM) | D (MM) |
|-----------|----------|--------|--------|--------|
| YBFAM-250 | 75 | 520 | 270 | 75 |

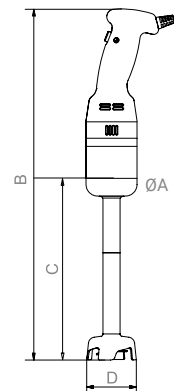

VARIABLE SPEED LIGHT

Arm shredders



YBV-300/ YBV-400



YBAM-300 YBAM-400 YBAM-500 YBAW-300

General features

Motor block

- Motor block housing made of highly resistant food-grade plastic to reduce weight and mitigate fatigue.
- Ergonomic handles for a good grip and improved user ergonomics.
- Ventilation grilles on the top for better engine ventilation and to prevent overheating.
- Thermal overload protection included.
- Variable speed. They have a shredder mode function (fixed fast speed).
- Intuitive liquid crystal digital display with 9 speed settings.
- Motor block with stabilised variable speed, allowing the speed to be maintained regardless of the load (quantity or type of food).

- Double safety ignition to prevent accidental ignition.
- Continuous use function by pressing a button, without having to hold down the button on the handle.
- Bayonet-type arm connection for easy and secure mounting.

Arm

- Fully removable stainless steel shafts for easy cleaning and maintenance.

Motor block - Codes, prices and dimensions

| MODEL | CODE | HZ | ØA (MM) | B (MM) | SPEED VARIABLE/FIXED (R.P.M.) | POWER (W) | VOLTAGE | WEIGHT (KG) | € |
|---------|----------|-------|---------|--------|-------------------------------|-----------|-------------|-------------|---|
| YBV-300 | 19114718 | 50/60 | 100 | 350 | 2.000 - 9.000/13.000 | 300 | 220-240V 1N | 1,8 | - |
| YBV-400 | 19114719 | 50/60 | 100 | 350 | 2.000 - 9.000/15.000 | 400 | 220-240V 1N | 2,1 | - |

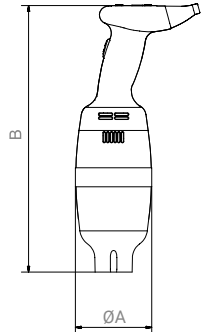

Arm - Codes, prices and dimensions

| MODEL | CODE | CAPACITY (L MIN-MAX) | C (MM) | D (MM) | WEIGHT (KG) | € |
|----------|----------|----------------------|--------|--------|-------------|---|
| YBAM-300 | 19114722 | 20-50 | 340 | 85 | 0,85 | - |
| YBAM-400 | 19114723 | 20-80 | 440 | 85 | 1 | - |
| YBAM-500 | 19114724 | 20-100 | 540 | 85 | 1,2 | - |
| YBAW-300 | 19114728 | 40 | 330 | 120 | 0,8 | - |

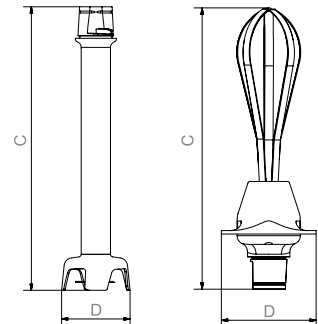

Accessory - Mixer support for pots

| MODEL | CODE | MAX POT Ø (MM) | € |
|--------|----------|----------------|---|
| YBS-40 | 19114730 | 400 | - |
| YBS-60 | 19114731 | 600 | - |

- Stainless steel holder for use with blender arms in pots..
- Easy to assemble, it allows the grinder to slide across the entire diameter of the pot for comfortable use.
- Not compatible with model YBFAM-250.



Arm shredders



YBV-450/ YBV-650



YBAM-450

YBAM-550

YBAM-650

YBAW-350

General features

Motor block

- Motor block casing made of highly resistant food-grade plastic.
- Ergonomic handles for a good grip and improved user ergonomics.
- Ventilation grilles on the top for better engine ventilation and to prevent overheating.
- Thermal overload protection included.
- Variable speed. They have a shredder mode function (fixed fast speed)..
- Intuitive liquid crystal digital display with 9 speed settings.
- Motor block with stabilised variable speed, allowing the speed to be maintained regardless of the load (quantity or type of food).
- Double safety ignition to prevent accidental ignition.

- Continuous use function by pressing a button, without having to hold down the button on the handle.
- Bayonet-type arm connection for easy and secure mounting.

Arm

- Fully removable stainless steel shafts for easy cleaning and maintenance.

Motor block - Codes, prices and dimensions

| MODEL | CODE | HZ | ØA (MM) | B (MM) | SPEED VARIABLE/FIXED (R.P.M.) | POWER (W) | VOLTAGE | WEIGHT (KG) | € |
|---------|----------|-------|---------|--------|-------------------------------|-----------|-------------|-------------|---|
| YBV-450 | 19114720 | 50/60 | 130 | 380 | 2.000 - 11.000/17.000 | 450 | 220-240V 1N | 3,2 | - |
| YBV-650 | 19114721 | 50/60 | 130 | 400 | 2.000 - 9.000/15.000 | 650 | 220-240V 1N | 3,6 | - |

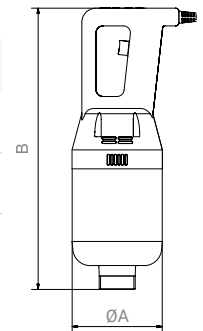

Arm - Codes, prices and dimensions

| MODEL | CODE | CAPACITY (L MIN-MAX) | C (MM) | D (MM) | WEIGHT (KG) | € |
|----------|----------|----------------------|--------|--------|-------------|---|
| YBAM-450 | 19114725 | 30-120 | 430 | 95 | 1,5 | - |
| YBAM-550 | 19114726 | 30-230 | 530 | 95 | 1,65 | - |
| YBAM-650 | 19114727 | 30-330 | 630 | 95 | 1,95 | - |
| YBAW-350 | 19114729 | 80 | 360 | 120 | 0,9 | - |

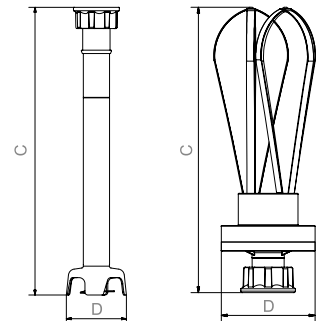

Accessory - Mixer support for pots

| MODEL | CODE | MAX POT Ø (MM) | € |
|--------|----------|----------------|---|
| YBS-40 | 19114730 | 400 | - |
| YBS-60 | 19114731 | 600 | - |

- Stainless steel holder for use with blender arms in pots.
- Easy to assemble, it allows the grinder to slide across the entire diameter of the pot for comfortable use.
- Not compatible with model YBFAM-250.



Potato peelers



YPS-10/F

General features

- Potato peeler made of AISI 304 stainless steel for strength and corrosion protection.
- Ventilated asynchronous motor for continuous and efficient operation.
- Abrasives on the plate and side walls are easily removable for cleaning and replacement.
- Transparent plexiglass cover for visual monitoring of production, with safety microswitch.
- Easy-to-use side control panel with multifunction digital timer.
- Electrical components protected by an ergonomic and secure plastic casing.
- Pressurised water inlet via solenoid valve to help clean the potatoes during the peeling process, removing skin residue and facilitating a more hygienic and efficient finish.
- Front discharge door, also equipped with a safety device.
- Manual discharge button.
- High support to improve ergonomics and facilitate the removal of waste and wash water.
- Included as standard equipment is a stainless steel drawer filter that helps collect and filter solid waste (peelings and potato scraps).

Codes and prices

| MODEL | CODE | HZ | LOAD CAPACITY (KG) | PRODUCTION (KG/H) | POWER (W) | VOLTAGE | € |
|----------|----------|----|--------------------|-------------------|-----------|-------------|---|
| YPS-10/F | 19114715 | 50 | 10 | 150 | 550 | 220-240V 1N | - |
| | 19114716 | 60 | | | | | - |
| YPS-18/F | 19115938 | 50 | 18 | 250 | 900 | 220-240V 1N | - |
| | 19115939 | 60 | | | | | - |

Dimensions

| MODEL | A (MM) | B (MM) | C (MM) |
|----------|--------|--------|--------|
| YPS-10/F | 660 | 530 | 1100 |
| YPS-18/F | 660 | 530 | 1200 |

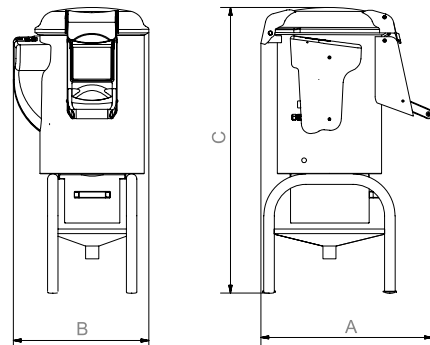

ONNERA GROUP



ACTIVELY SUPPORTING

