



WASHING

SANITARY BARRIERS LMED RANGE LMED-16/22 TP2



CHARACTERISTICS

TP2

- 7" touch screen easy to use and fully programmable, display on dirty side.
- Connection USB. Free software online for programming, telemetry, data analysis...
- Videos on display (instructions...)
- 37 languages.
- 8 dosing signals as standard.

OUTSTANDING FEATURES

- Automatic positioning of drum.
- 2 water inlets.
- Wet cleaning features ready.
- G-FACTOR 350.
- Telemetry as standard.
- Heating: electric, steam, and dual heating model (electric+steam).

EFFICIENCY

- Intelligent consumption.
- Optimal loading.
- Water Recovery tanks ready: KRS
- Low water consumption.
- High G-FACTOR: reduced residual moisture > reduced drying time.

CONNECTIVITY

- IoT FagorKonnnect.
- Remote technical service.
- Laundry management.

ERGONOMICS

- Huge door opening making loading/unloading easier.
- Easy friendly drum opening by push button.
- Loading height: door base 670 mm.

MAINTENANCE

- Electric components on the left side, mechanical components on the right side and connections on the top (protected from water and detergents).
- Central drain as standard.

- Technical menu: statistics, alarms, autotest, data recovery for technicians and maintenance.

OTHERS

- 2 opposed doors. Pass-through barrier washer.
- Ready to be connected to dosing pumps.
- Grey skinplate outer casing.
- Drum and vat in stainless steel AISI 304.
- Frequency inverter to control imbalance.
- Electric, steam or dual heating.
- CE approved product.

OPTIONS

- 1-door opening (single side operation).
- 7" second screen on clean side.
- Auto Weight: automatic weighing sensor system on feet (Includes kit with 6 extra dosing signals).
- Relay card with 6 extra dosing signals: up to 14 signals.
- Third water inlet.
- Double drain.
- Titration valve.
- Side drain valve.
- Low steam pressure (0,5 bar).
- Detergent box with 4 compartments.
- Electric drum motor brake.
- UPS Option (in case of power failure).
- End of cycle light alarm.
- Plinth to align loading height (door base at 850mm).
- Stainless steel AISI 304 outer casing.
- Stainless steel AISI 304 sanitary frame.
- Other voltages.

	UNIT.	LMED-16 TP2	LMED-22 TP2		
DRUM					
Capacity 1:9	Kg	18	24,5		
	Lb	39,7	54		
Capacity 1:10	Kg	16	22		
	Lb	35,3	48,5		
Volume	l	158	220		
	ft³	5,58	7,77		
Diameter	mm	633	633		
	inch	24,9	24,9		
Depth	mm	500	700		
	inch	19,7	27,6		
Number of compartments	Nº.	1	1		
Pullman petition of drum		N/A	N/A		
GENERAL DETAILS					
Washing speed	r.p.m.	45	45		
Spining speed	r.p.m.	1.000	1.000		
G Factor		350	350		
Maximum force transmitted	KN	5,5 ±1,12	6,25 ±1,54		
Frequency-dynamic force	Hz	15,4	15,4		
Sound level	dB	<70	< 70		
Double drain		Opt	Opt		
Weighing System		Opt	Opt		
DOOR					
Drum opening dimensions	mm	400x315	400x315		
	inch	15,7x12,4	15,7x12,4		
Vat opening dimensions	mm	455x415	455x415		
	inch	17,9x16,3	17,9x16,3		
Height base door	mm	670	670		
	inch	26,4	26,4		
POWER					
Motor	kW	2,2	2,2		
Electric heating power	kW	12	18		
Max. power (Electric model)	kW	14,2	20,2		
Max. power (Steam model)	kW	2,2	2,2		
CONNECTIONS		ELECTRIC / DUAL	STEAM	ELECTRIC / DUAL	STEAM
Tension 230V- I + N + T	Nº x mm2/A	-	3 x 1,5 / 6A	-	3 x 1,5 / 6A
Tension 230V- III + T	Nº x mm2/A	4 x 10 / 40A	-	4 x 10 / 50A	-
Tension 400V- III + N + T	Nº x mm2/A	5 x 6 / 25A	-	5 x 6 / 32A	-
Steam inlet (Steam)	mm	20/27	20/27		
	inch	3/4"	3/4"		
Maximum steam consumption (Steam)	Kg/h	9	12		
Water inlet	mm	20/27	20/27		
	inch	3/4"	3/4"		
Water main pressure	bar	3 - 5	3 - 5		
	psi	43 - 72	43 - 72		
Water consumption	Lit/h	104*/128**	143*/176**		
Drain	mm	80	80		
	inch	3"	3"		
Drain Flow	Lit/min	200	200		
	cfm	5,65	5,65		
DIMENSIONS / PACKING DIMENSIONS					
Net width / Gross width	mm	984 / 1.072	1.184/ 1.262		
	inch	38,7 / 42,2	46,6 / 49,7		
Net depth / Gross depth	mm	914 / 1.102	914 / 1.102		
	inch	36 / 43,4	36 / 43,4		
Net height / Gross height	mm	1.398 / 1.530	1.398 / 1.530		
	inch	55 / 60,2	55 / 60,2		
Net weight / Gross weight	Kg	438 / 459	471 / 494		
	Lb	966 / 1011,9	1.038 / 1.089,1		
Volume	m³	1,60 / 1,81	1,88 / 2,13		
	ft³	56,5 / 63,8	66,39 / 75,1		

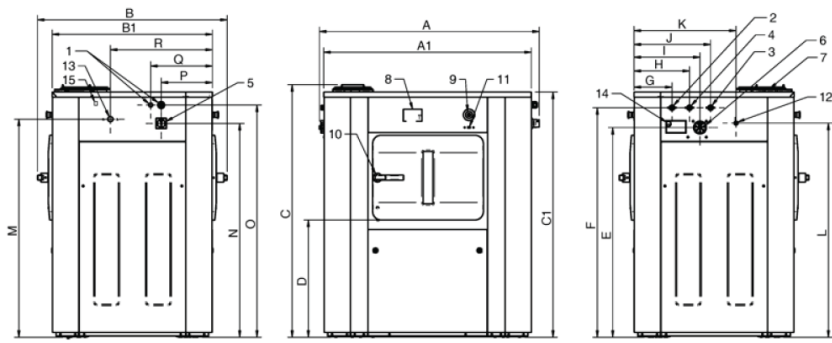

- 01. Electrical connexion
- 02. Hot water
- 03. Cold water
- 04. Soft water
- 05. Main switch
- 06. Liquid products intel
- 07. Detergent box (option)
- 08. Control panel
- 09. Emergency stop
- 10. Door opening
- 11. USB port
- 12. Dosing pumps connexion
- 13. Steam intel
- 14. Exhaust

	A	B	C	A1	B1	C1	D	E	F	G	H	I	J	K	L	M	N	O	P	Q	R
LMED-16	1.054	1.082	1.426	984	914	1.385	661	1.184	1.296	217	317	377	437	582	1.209	1.231	1.207	1.311	292	352	582
LMED-22	1.254	1.082	1.426	1.184	914	1.385	661	1.184	1.296	217	317	377	437	582	1.209	1.231	1.207	1.311	292	352	582