



FINISHING

ELECTRIC GENERATORS FOR STEAM PRODUCTION AND PROFESSIONAL IRONING TABLE BETA-3 / SIMBA-MINI / MPA



BETA-3



SIMBA-MINI



MPA+BETA-3

CHARACTERISTICS

BETA-3

- Electric steam boiler of 1,8 lit. capacity (1 kW) with iron.
- Small, thermally insulated, electric steam boiler. Die-cast aluminium boiler. Manually operated water feeding. Drinking water required for its functioning.
- Automatic pressure control by thermostat with fixed setting.
- Trolley as option.

SIMBA-MINI

- Stainless steel electric steam boiler, complete with electric steam iron.
- Water level indicator with warning light for empty boiler.
- Three safety devices fitted on the boiler: pressure switch, safety valve and safety thermostat.
- Manually water feed.
- Casters available on request.

MPA

- Folding ironing table with electrically heated board and built in suction unit.

OPTIONS

- 5 feet trolley + wheels for BETA-3.
- Wheels support for SIMBA-MINI.

TECHNICAL DATA

ELECTRIC GENERATORS FOR STEAM PRODUCTION AND PROFESSIONAL IRONING TABLE | BETA-3 / SIMBA-MINI / MPA

	UNIT.	BETA-3	SIMBA-MINI
GENERAL DETAILS			
Boiler Heater	kW	1,0	1,45
Iron Heater	kW	0,830	0,800
Boiler Capacity	l	1,80	5,0
CONNECTIONS			
Autonomy	-	2/3	5/6
Operating pressure	BAR	2,6	2,8
DIMENSIONS			
Dimensions	mm	230 x 420 x 300	225 x 450 x 820
Net weight	kg	7,5	11
Gross weight	kg	9	15
Packing dimensions	mm	480 x 390 x 300	480 x 390 x 300
OTHERS			
Voltage	Hz	230V 50/60	230V 50/60

	UNIT.	MPA
GENERAL DETAILS		
Board heater	W	600
Vacuum Motor	W	100
DIMENSIONS		
Working dimensions	mm	1.100 x 380 x 240
Dimensions	mm	1.380 x 380 x 930
Net weight	kg	22
Gross weight	kg	32
Packing dimensions	mm	1.460 x 460 x 380
OTHERS		
Voltage	Hz	230V 50/60



FINISHING

STEAM GENERATOR MAXI-24

CHARACTERISTICS

- Electric and automatic steam boiler MAXI-24 to supply steam to models without boiler.
- Available from 12 to 22 kW.
- Water feed can be connected directly to the water mains or to a condensate tank.
- Regulation of the working steam pressure is adjustable between 1 and 7 bar.
- The boiler shed is manufactured in accordance to the current PED regulations.

OPTIONS

- Stainless steel condensate tank.



TECHNICAL DATA

STEAM GENERATOR | MAXI-24

	UNIT.	MAXI-24
GENERAL DETAILS		
Boiler capacity	l	24,9
Steam pressure	Bar	0,3 - 7
Working temperature	°C	+5 ÷ +80
Working humidity	-	90% max
POWER		
Boiler heaters	kW	12-15-22
Steam production	Kg/h	16-20-29,7
Pump motor power	HP	0,5
CONNECTIONS		
Water feeding inlet	Inch	1/2"
Boiler exhaust	Inch	1/2"
Steam inlet	Inch	1/2"
Condensate return with valve	Inch	1/2"
DIMENSIONS		
Dimensions	mm	580x660x780
Net weight	kg	85
Gross weight	kg	111
Packing dimensions	mm	880x730x1.050
OTHERS		
Voltage	Hz	230/400 V III 50/60
Sound level	dB	<70

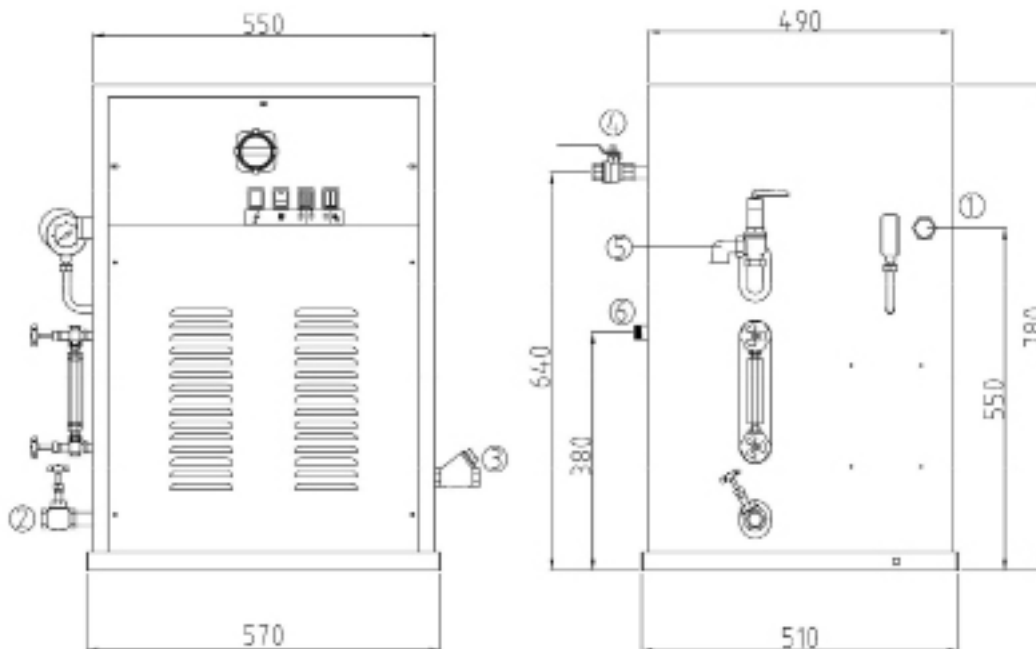

1. PG21 power supply inlet.
2. Boiler exhaust.
3. Water feeding inlet.
4. Steam inlet.
5. Safety valve.
6. Condensate return with valve.